

2

1

ITEM NO.	PART NUMBER	DESCRIPTION	QTY.
1	TT-FSNR-BA375F	4" Preburster Blade Screw	1
2	TT-HEAD-4BLD	4" Blade	1
3	TT-TCHEAD-NOSE	Triple Chuck Head Nose	1
4	TT-TCHEAD-GRPR	Triple Chuck Gripper	1
5	TT-TCHEAD-OR125	Triple Chuck O-Ring	1
6	TT-TC-SPRING	Triple Chuck Spring	1

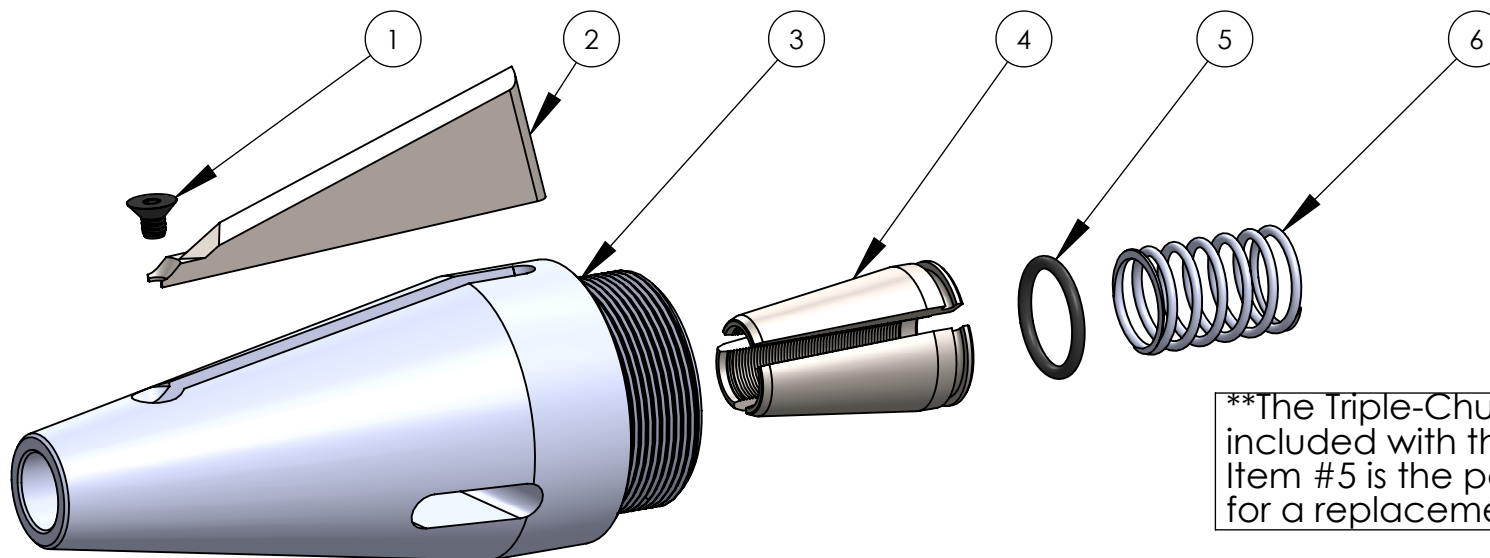
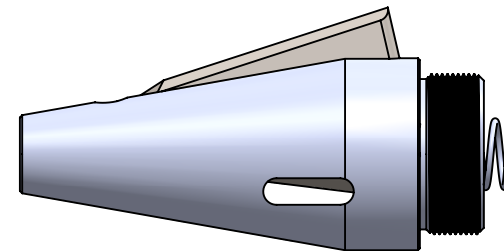

**\*\*The Triple-Chuck O-Ring is included with the Gripper. Item #5 is the part number for a replacement O-Ring\*\***

**PROPRIETARY AND CONFIDENTIAL**  
 THE INFORMATION CONTAINED IN THIS DRAWING IS THE SOLE PROPERTY OF TRIC TOOLS, INC. ANY REPRODUCTION IN PART OR AS A WHOLE WITHOUT THE WRITTEN PERMISSION OF TRIC TOOLS, INC. IS PROHIBITED.

UNLESS OTHERWISE SPECIFIED:

DIMENSIONS ARE IN INCHES  
 TOLERANCES:  
 FRACTIONAL ±  
 ANGULAR: MACH ± BEND ±  
 TWO PLACE DECIMAL ±  
 THREE PLACE DECIMAL ±

INTERPRET GEOMETRIC TOLERANCING PER:

MATERIAL

FINISH

DO NOT SCALE DRAWING

	NAME	DATE
DRAWN		
CHECKED	ZWD	1/14/2022
ENG APPR.		
MFG APPR.		
Q.A.		
COMMENTS:		

TRIC Tools, Inc.		
TITLE: <b>Triple Chuck Nose Assembly</b>		
SIZE <b>A</b>	DWG. NO. TTA-TCNOSE-ASM	REV <b>A</b>
SCALE: 1:2	WEIGHT: 8 lbs.	SHEET 1 OF 1

2

1