

2

1

ITEM NO.	PART NUMBER	DESCRIPTION	QTY.
1	TT-FSNR-BA313H	Shoulder Screw (Short)	2
2	TTA-YOKE-ARMP	Monolithic Gripper Yoke Arm Assembly	1
3	TT-YOKE-ASM	Yoke Tower	2
4	TT-FSNR-YLW	1/4" Split Lock Washer	2
5	TT-GRPR-34CG	3/4" Clyde Gripper Pair	1

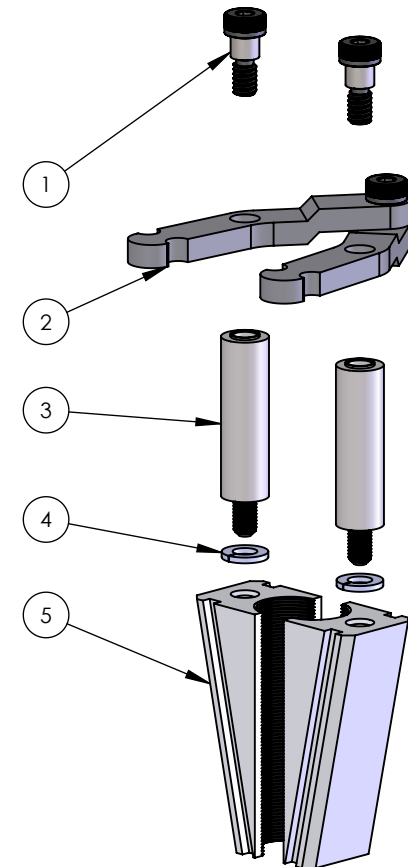

B

B

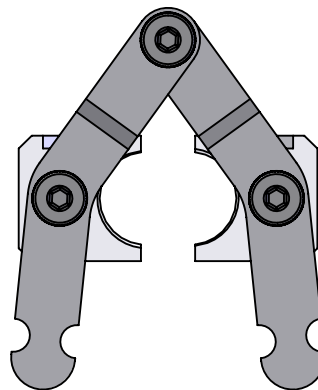
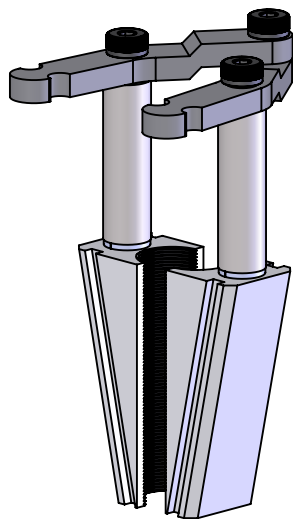

Items 1-4 make up TTA-GA-YASM

A

A

PROPRIETARY AND CONFIDENTIAL
 THE INFORMATION CONTAINED IN THIS DRAWING IS THE SOLE PROPERTY OF **TRIC TOOLS, INC.** ANY REPRODUCTION IN PART OR AS A WHOLE WITHOUT THE WRITTEN PERMISSION OF **TRIC TOOLS, INC.** IS PROHIBITED.

		UNLESS OTHERWISE SPECIFIED:		NAME	DATE
		DIMENSIONS ARE IN INCHES	DRAWN		
		TOLERANCES:	CHECKED	ZWD	7/29/2022
		FRACTIONAL ±	ENG APPR.		
		ANGULAR: MACH ±0.5°	MFG APPR.		
		TWO PLACE DECIMAL ±0.010	Q.A.		
		THREE PLACE DECIMAL ±0.005	COMMENTS:		
		INTERPRET GEOMETRIC TOLERANCING PER:	-DEBURR all sharp edges.		
		MATERIAL			
NEXT ASSY	USED ON	FINISH			
APPLICATION		DO NOT SCALE DRAWING			

TRIC Tools, Inc.		
TITLE:		
3/4" Clyde Gripper Assembly		
SIZE	DWG. NO.	REV
A	TTA-GA-34CG	
SCALE: 1:2	WEIGHT: 2 lbs	SHEET 1 OF 1

2

1