

B

B

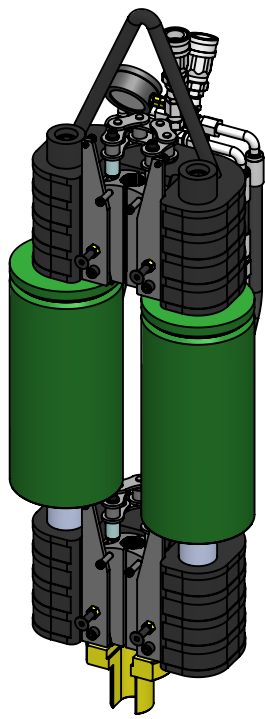
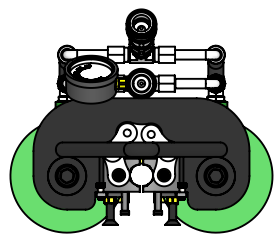
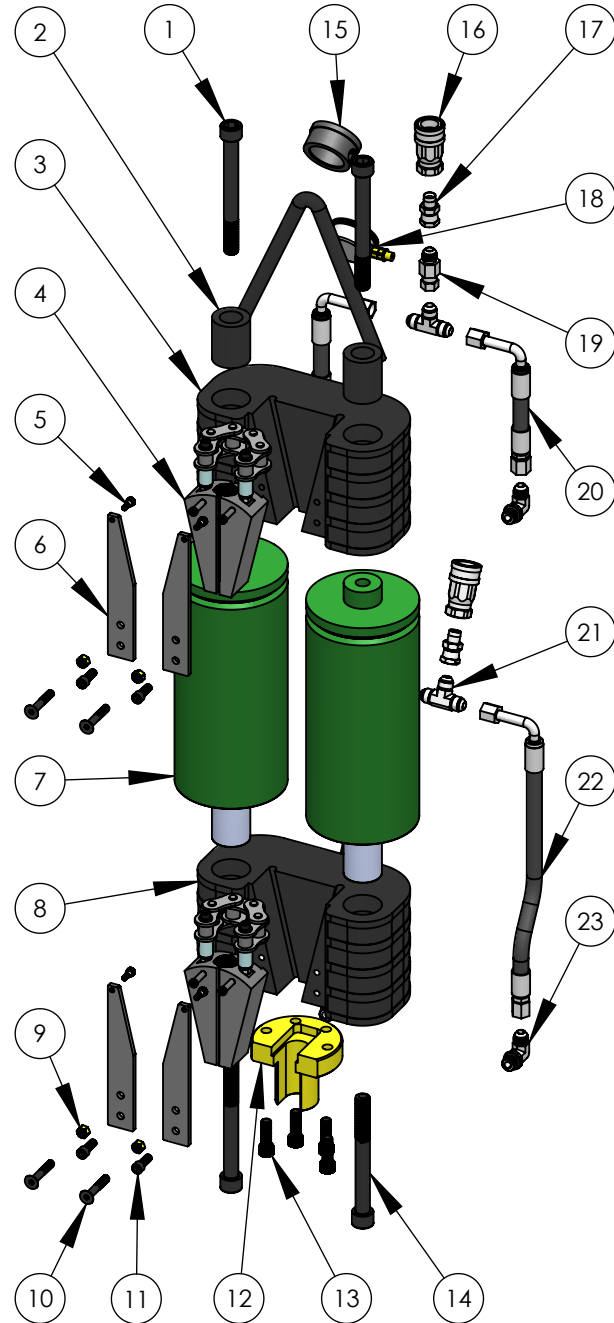

A

A

ITEM NO.	PART NUMBER	DESCRIPTION	QTY.
1	TT-FSNR-HA7000C	M100 Handle Bolt	2
2	TT-HAND-TRIL	M100 Weldment Handle	1
3	TT-BRDG-100F	HFHD-100 Pulling Bridge	1
4	TTA-GA-M118	1 1/8" Gripper Assembly	2
5	TT-FSNR-BA313H	Shoulder Screw (Short)	4
6	TT-GCPS-100P	100 Ton Cover Plates (Pair)	2
7	TT-CYLN-100A	M100 Cylinder Assembly	2
8	TT-BRDG-100G	HFHD-100 Retaining Bridge	1
9	TT-FSNR-DAN	M100 Cover Plate Nut	4
10	TT-FSNR-DA2250F	M100 Cover Plate Screw Long	4
11	TT-FSNR-DA750C	M100 Cover Plate Screw	4
12	TT-NOSE-FB125	100 Ton Nose	1
13	TT-FSNR-FB1500C	M100 Nose Bolt	4
14	TT-FSNR-HA5500C	M100 Lower Bridge Bolts	2
15	TT-HFIT-GCP	Gauge Cover Protector	1
16	TT-HFIT-6600F	Parker Female 6600 Fitting	2
17	TT-HFIT-REDS	1/2" JIC/NPT Straight Adapter	2
18	TT-HFIT-PG6KMP	6K Pressure Gauge	1
19	TT-HFIT-T34S	Swivel Fitting	1
20	TT-HOSE-100S	M100 Hose [Short]	2
21	TT-HFIT-THF	Tee, JIC	2
22	TT-HOSE-100L	M100 Hose (Long)	2
23	TT-HFIT-LOB12	1/2" Elbow @ 90-Deg.	4

DRAWN		NAME	DATE	TRIC Tools, Inc. TITLE: M100 Pulling Ram SIZE A DWG. NO. TTP-HFHD-100 REV A SCALE: 1:10 WEIGHT: 380 lbs SHEET 1 OF 1	
CHECKED		ZWD	10/26/2021		
ENG APPR.					
MFG APPR.					
Q.A.					
COMMENTS:					